

# STAINLESS STEEL BALL BUSHINGS

These stainless steel ball bushings have the same boundary dimensions & tolerances as the standard ball bushings (open & closed).

They are used where corrosion resistance is required for example in the food and chemical industries.

Technical specifications of the materials used:

Outer Ring & Balls 1.4125 (SUS440C)  
 Steel Cage 1.4301 (SUS304)  
 End Plates 1.4021 (SUS420)

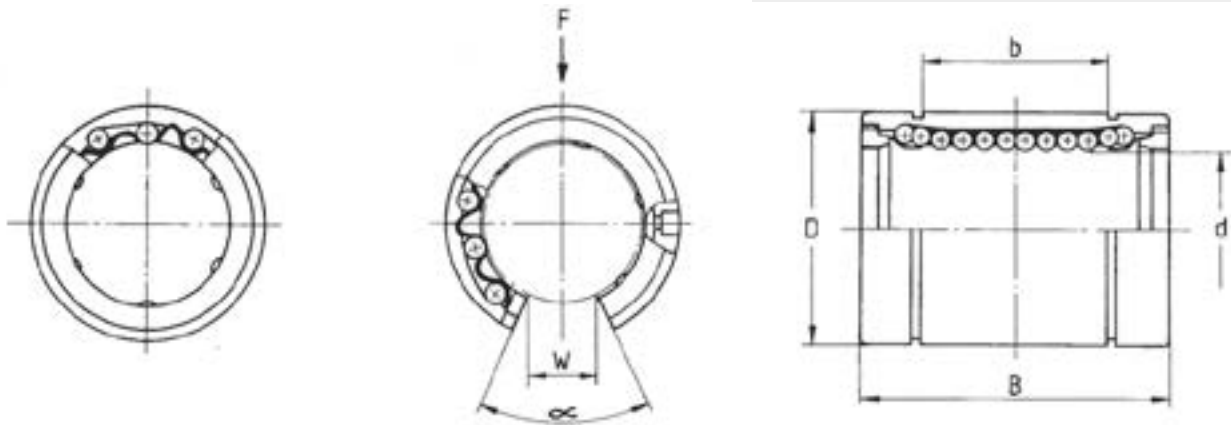

Closed Type	d	D	B	b	Ball circuits	Load C (N)	Load C <sub>0</sub> (N)	Weight (kg)	Circlip Size
KB50-008	8	16	25	14	4	270	410	0.02	16x1
KB50-012	12	22	32	20	4	520	790	0.05	22x1.2
KB50-016	16	26	36	22	4	590	910	0.06	27x1.2
KB50-020	20	32	45	28	5	880	1400	0.10	33x1.5
KB50-025	25	40	58	40	6	1000	1600	0.24	42x1.75
KB50-030	30	47	68	48	6	1600	2800	0.36	48x1.75
KB50-040	40	62	80	56	6	2200	4100	0.77	62x2
KB50-050	50	75	100	72	6	3900	8100	1.25	75x2.5

KB50's also available for shaft sizes 3, 4, 5, 10 & 60. Please see website for details.

Open Type	d	D	B	b	alpha	W	Ball Circuits	Load C (N)	Load C <sub>0</sub> (N)	Weight (kg)
KB53-012	12	22	32	20	78	7.5	3	530	830	0.04
KB53-016	16	26	36	22	78	10	3	600	940	0.05
KB53-020	20	32	45	28	60	10	4	960	1570	0.08
KB53-025	25	40	58	40	60	12.5	5	1020	1720	0.20
KB53-030	30	47	68	48	50	12.5	5	1640	3000	0.31
KB53-040	40	62	80	56	50	16.8	5	2250	4400	0.77
KB53-050	50	75	100	72	50	21	5	4000	8680	1.08