

**ECCENTRIC ADJUSTABLE  
CR BEARINGS**

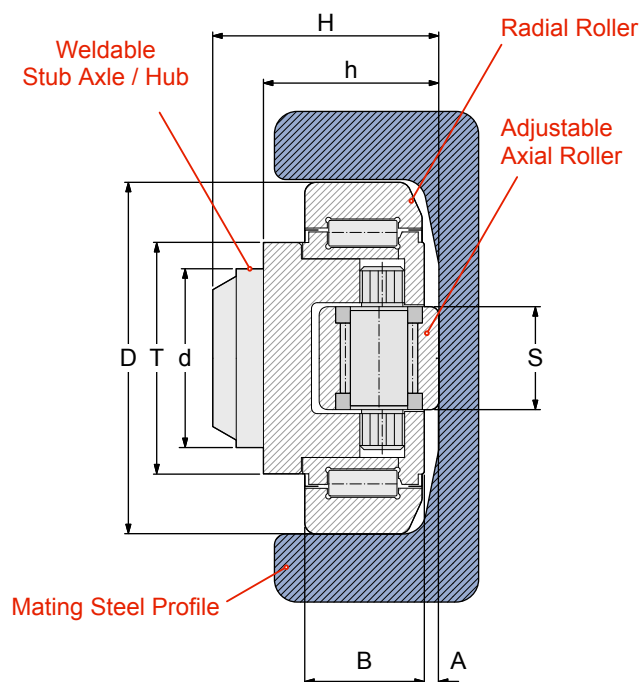

Our adjustable Combined Roller bearings have the side (axial) roller mounted on an eccentric shaft which allows for adjustment of their height (dimension 'h' on the chart below).

BEARING REFERENCE	Dimensions (mm)									C kN	C <sub>0</sub> kN	C <sub>a</sub> kN	C <sub>oa</sub> kN	Maximum RPM	PROFILE REF	PLATE REF
	D	T	d	H	h	B	A	S	r							
4.454	62	42	30	37.5	30.5 - 32	20	4	20	3	31	35.5	11	11	900	2890	PL 0
4.455	70.1	48	35	44	36 - 37.5	23	4	20	4	45	51	18	18	900	2867	PL 1
4.456	77.7	54	40	48	37 - 38.5	23	3.5	26	4	48	56.8	18	18	800	2810	PL 2
4.457	77.7	54	40	40	29 - 30.5	23	3.5	26	4	48	56.8	18	18	800	3019	
4.458	88.4	59	45	57	44 - 45.5	30	4	26	4	68	72	23	23	750	2811	PL 3
4.459	101.2	69	50	46	33 - 35	26	4.5	30	3	73	82	25	27	700	2912	
4.460	107.7	69	55	54	40 - 42	31	4	30	5	81	95	25	27	650	3100	
4.461	107.7	69	60	69	55 - 57	31	4	30	5	81	95	25	27	650	2862	PL 4
4.462	123	80	60	72.3	56 - 60	37	4.5	34	5	110	132	31	36	550	2891	PL 4
4.463	149	103	60	78.5	58.5 - 62.5	45	6	34	3	151	192	31	36	450	2757	PL 6

C = Dynamic Load Capacity for radial roller  
 C<sub>0</sub> = Static Load Capacity for radial roller  
 C<sub>a</sub> = Dynamic Load Capacity for axial (side) roller  
 C<sub>oa</sub> = Static Load Capacity for axial roller

**For guidance on how to adjust the height of the face roller of our eccentric CR bearings please see page 34.**

STANDARD CHANNEL

2912

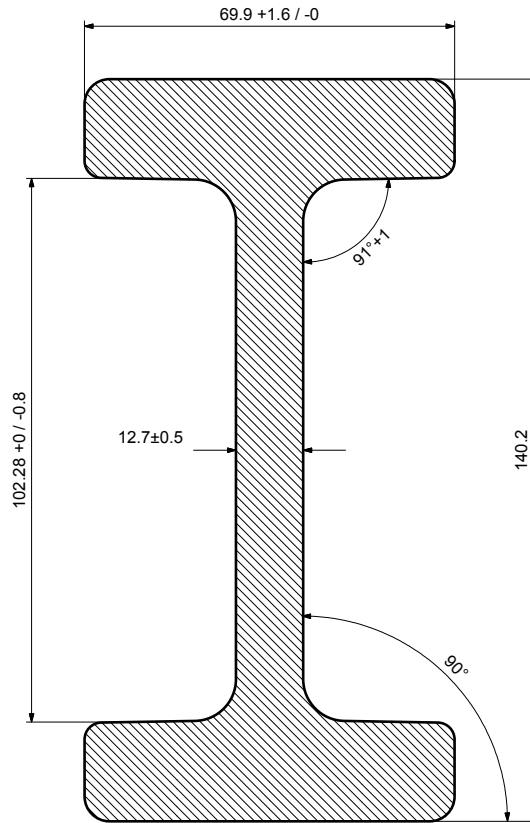

Profile Reference	Web Height mm	Flange Width mm	Channel Height mm	Weight kg / metre	Bearing Reference	Plate Reference	Section Shape
2912	140.2	69.9	102.28	31.2	4.059	-	I Section

PROFILE REFERENCE: **2912**

Weight: 31.2kg per metre

Moment of Area (Wx): 156cm<sup>3</sup>

Material: S450J2

Use with our:

**4.059** Standard Combined Roller Bearing

**4.459** Eccentric Adjustable CR Bearing

Other suitable bearings:

**4.077** Shim Adjustable CR Bearing

[www.euro-bearings.com](http://www.euro-bearings.com)